

LIGGING: Leuvensestraat 50-52, 3010 Kessel-lo

Nr.50 : 1 duplex appartement / 5 kamers

Nr.52 : 1 handel

Aanpassing na VGO dossiernummer:VGO2023/0234

11-09-2023

Datum Collegebeslissing toekenning officiële binnenummering

02/12/2011

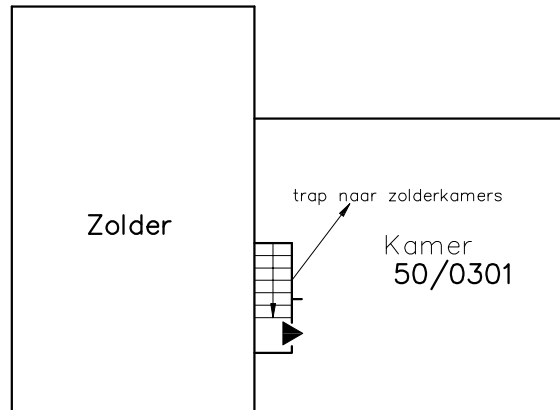

Verdieping 3

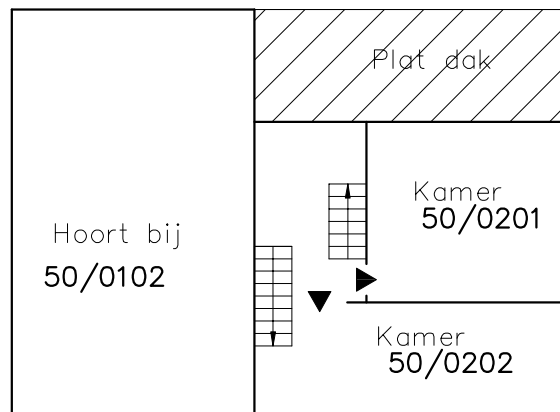

Verdieping 2

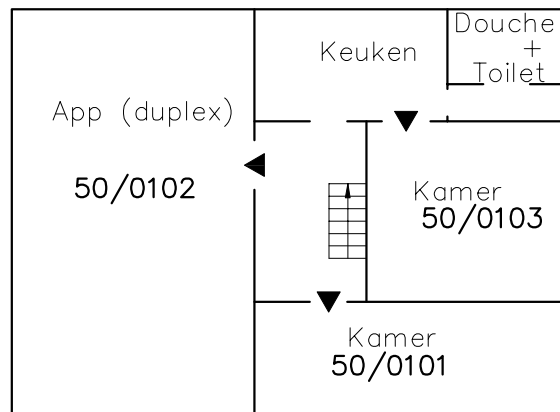

Verdieping 1

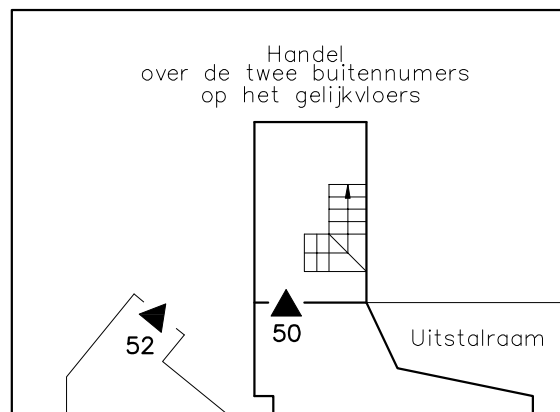

Gelijkvloers

Leuvensestraat