

LOBEMENT 70/1

ED1

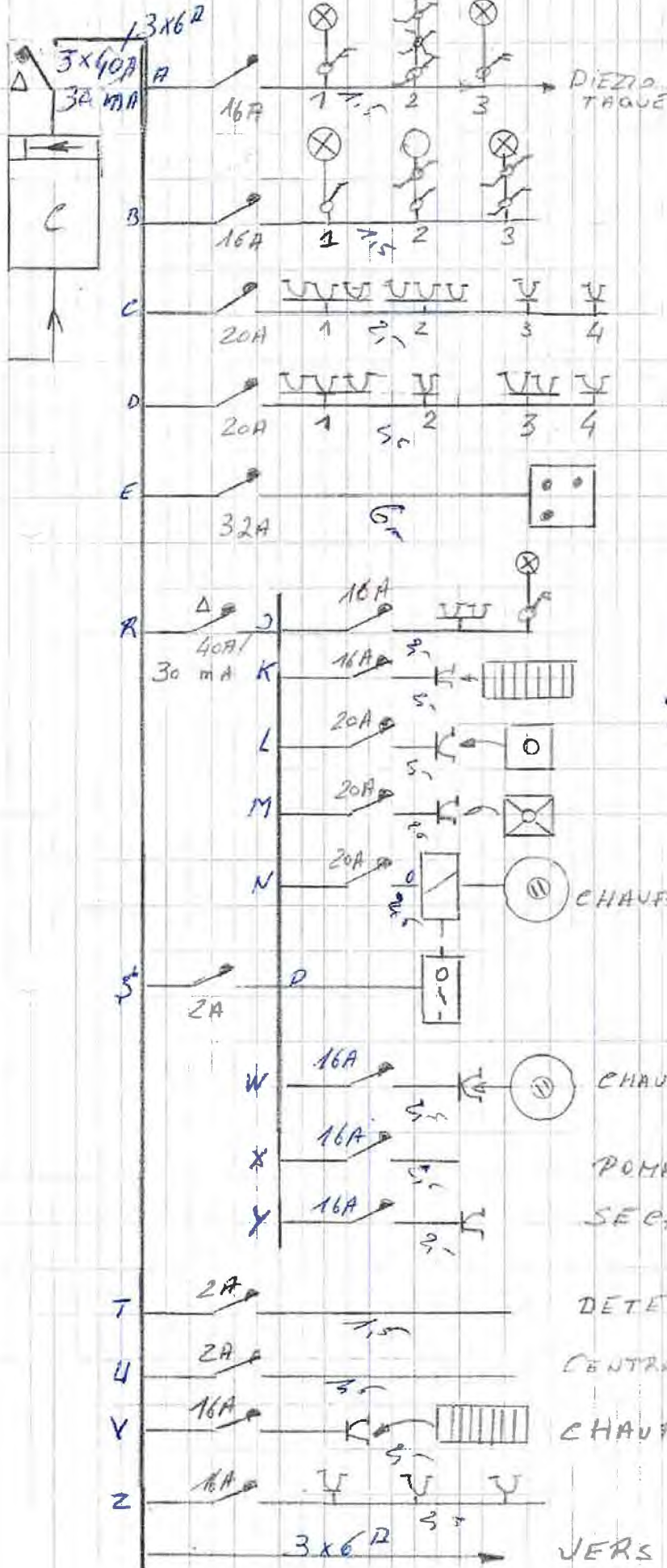

M. LELOUP
 70/1 me de ginschop
 1300 LIND
Yokou

H. J. VAN JEMMELDEN
 KEURMEESTER, STREEKREGISTEREERD
 Inspecteur (1/1)
 ROOFHOOFDZAKMEESTER
 09/10/1910

CHAUFFE-EAU SDB
 CHAUFFE-EAU CUISINE
 POMPE BAIGNOIRE
 SECHOIR
 DETECTEUR GAZ
 CENTRALE SYSTEME ALARME
 CHAUFFAGE CUISINE
 VERS ED2 VOIR VE:ASO

CD2

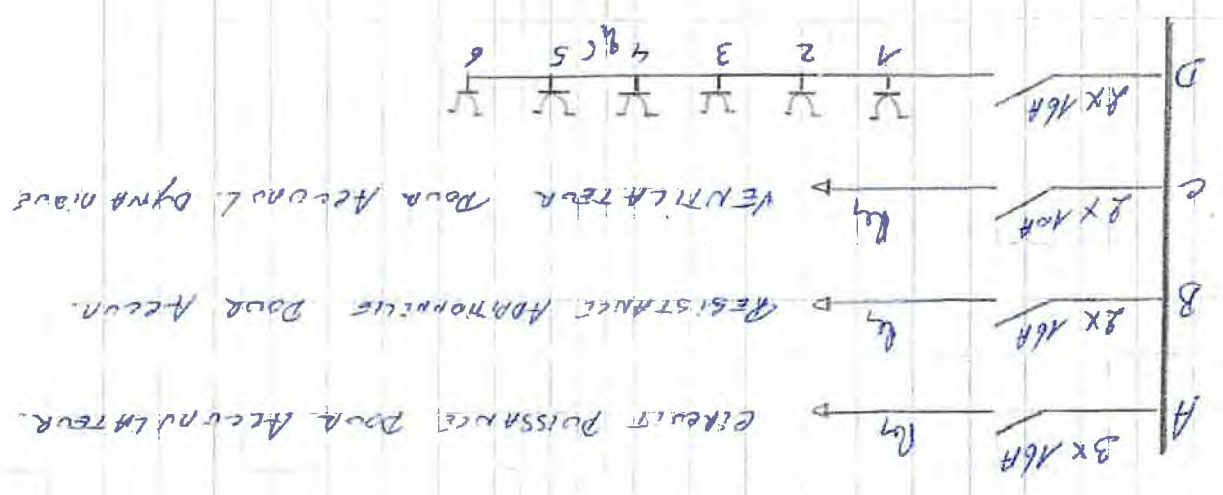

LOGEMENT 70/1

FRIGO
21

22

23

24

3 89

D3 (CD2)
ADSL
BELGACOM

A1

C1

E.M.

SURBELEVEUR
C3

LAVE-VAISSELLE
M

Niv. 10.12

3 81

RADIAEUR
V

25

A2

D2 (CD2)

BOILER
K

3 30

SECHOIR

E.M.

M.A.L.

HOTTE

H24

BOILER
DE
E

TAGUE
PIERRE
U

A1

D.E.P.

J. VAN HEMELLEN
KEURINGSORGANISME VZW
inspecteur (11)
ROOFTHOOFTE Aime

09/09/09

J. VAN HEMELLEN
KEURINGSORGANISME VZW
insp. (11)
ROOFT Aime

+ 10.00

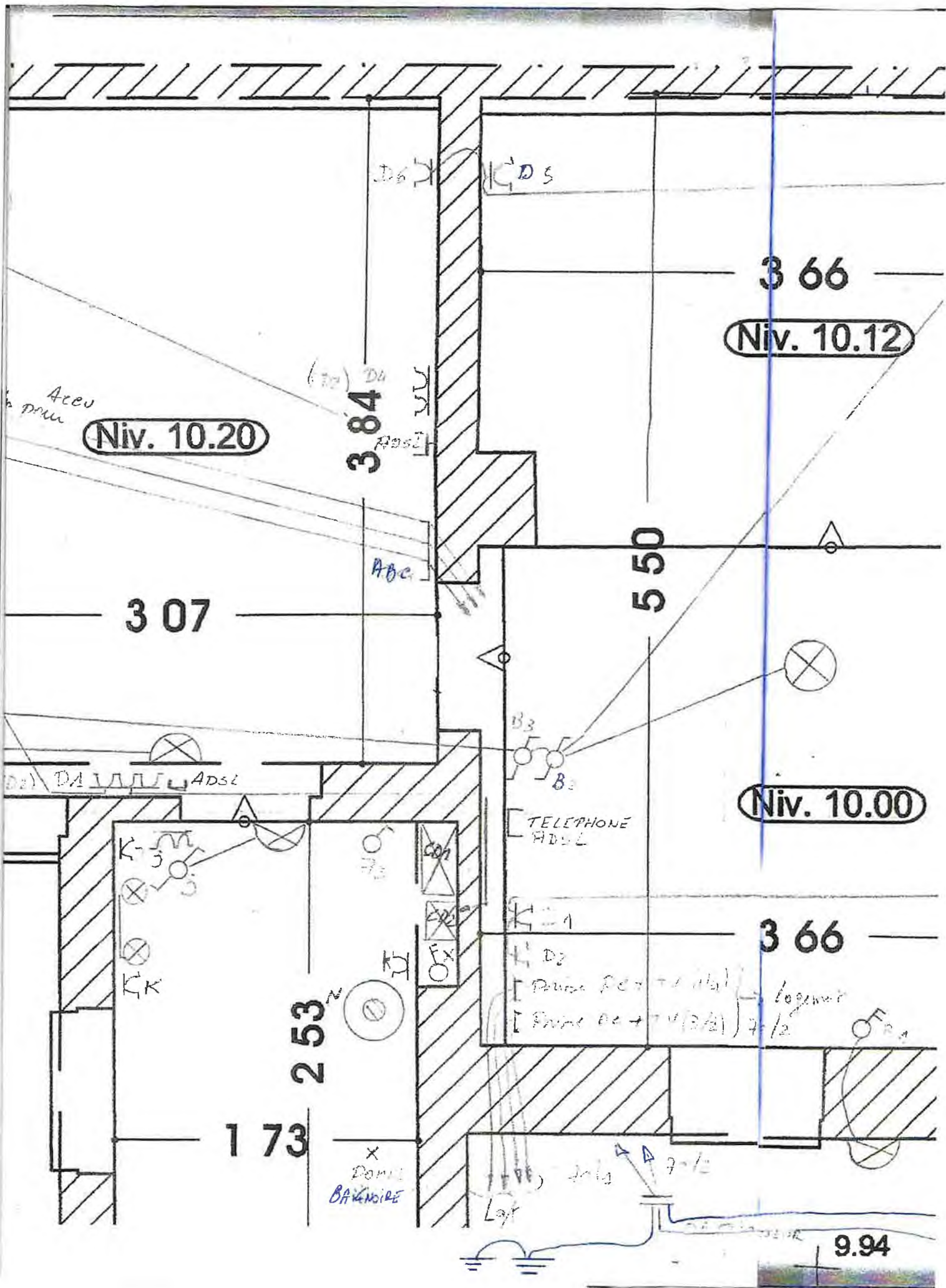

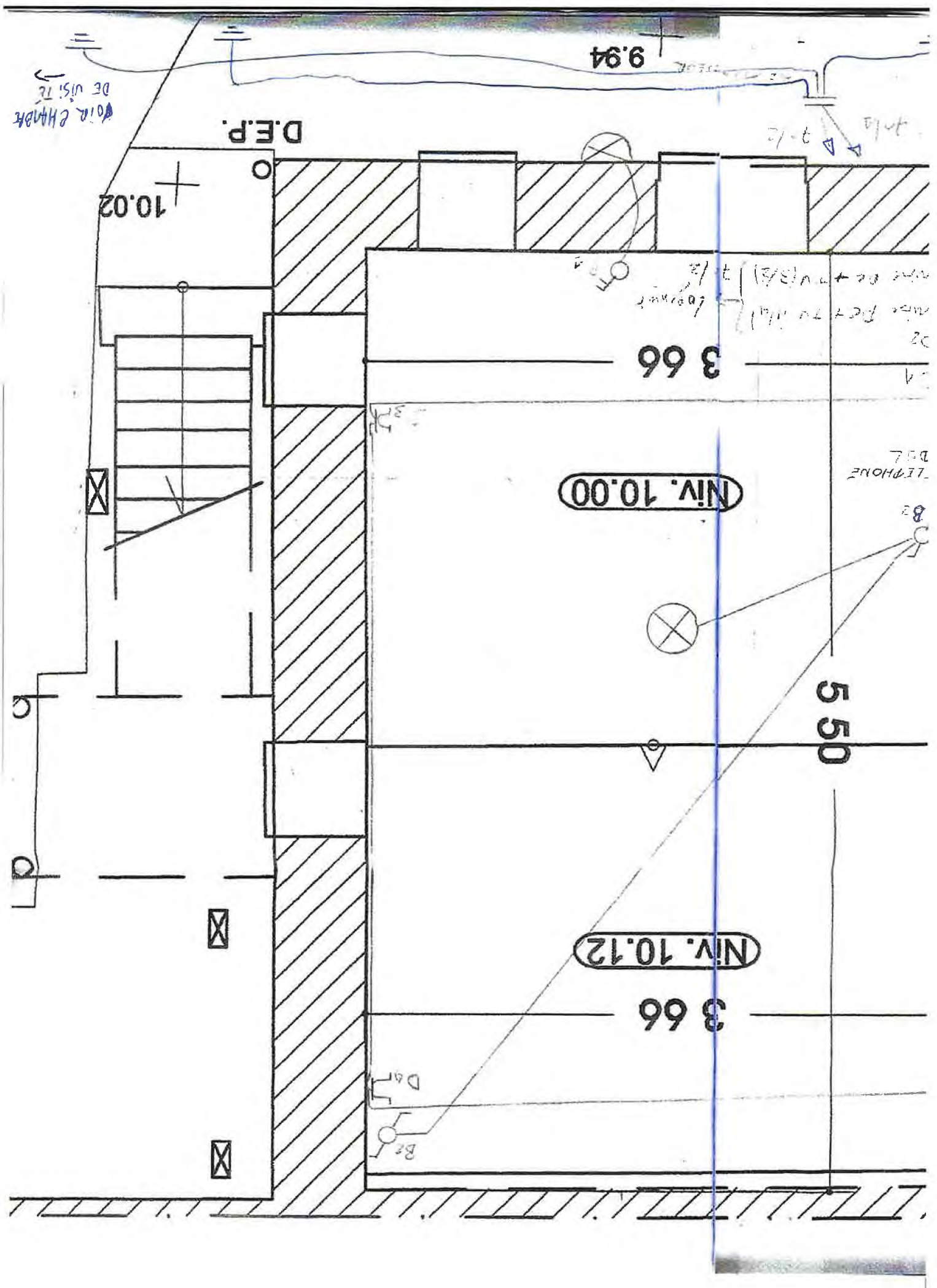

9.94

D.E.P.

10.02

3 66

Niv. 10.00

5 50

Niv. 10.12

3 66

voir CHASSE DE VISITE

voir de + (B/S) 1/2
voir de + (B/S) 1/2
voir de + (B/S) 1/2

TELEPHONE D.P.L.

B2

D4
B2

